

Rotofast™

INSTALLATION STEPS

1

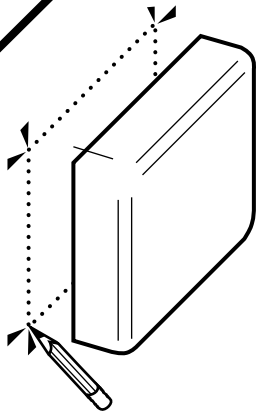

- Position panel.
- Mark its location.

2

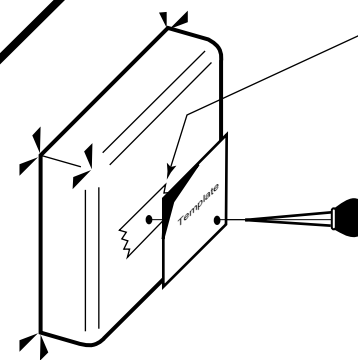

- Put masking tape on panel face at anchor locations (optional)
- Position template; Push scratch awl through panel at template marking hole.
- Indent wallboard behind panel.
- **(Note: to mark harder wall material, i.e. concrete block, after marking the panel with the scratch awl, put a common nail in the hole and tap with a hammer.)**

3

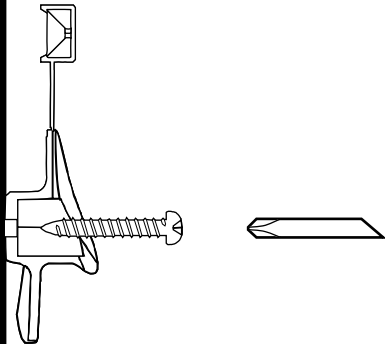

- Screw Rotofast panel anchors to wall at pre-marked locations.
- (Consult manufacturer for recommended fasteners to use with Rotofast anchors)
- **(Note: do not over-tighten, anchors should be hand tight and able to turn on screw shaft)**

4

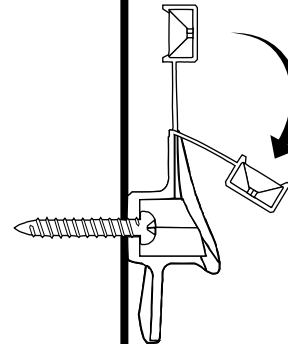

- Push hex insert firmly into anchor body.

5

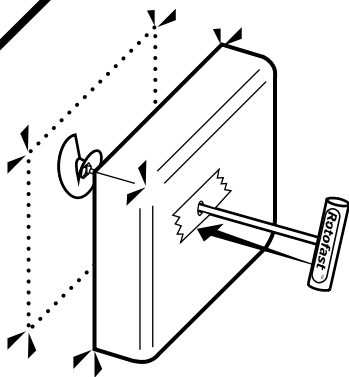

- Re-position panel.
- Push pointed hex driver through panel to engage Rotofast anchors.
- **(Note: fully engage hex driver with metal insert before turning)**

6

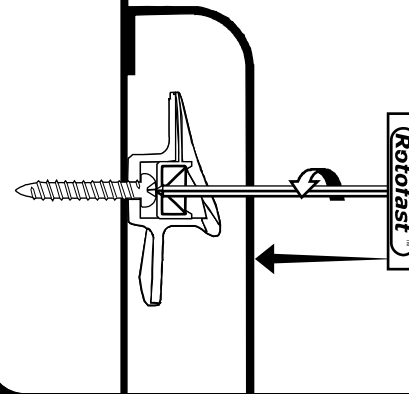

- Turn Rotofast panel anchors counter-clockwise (left), while pushing panel towards wall.
- **(Note: 1-2 turns, do not over-tighten)**
- Remove masking tape. Lightly rub fabric to hide hole locations.

To place an order or for technical information contact Rotofast Inc. at 1.888.545.7444 or visit our website at www.rotofast.com

?